



e-bike Challenge

Minneapolis Convention Center - Hall A
Minneapolis, MN
March 23-24, 2019

Dear Exhibitor:

Brede Exposition Services is pleased to have been selected as the Official Service Contractor for the upcoming **E-bike Challenge**. We recognize that your participation in this event is a vital part of your firm's marketing program, and we want to do everything possible to make it profitable and rewarding for you.

Included in this service manual are forms for ordering various services and equipment. The Brede forms are to be returned to our office, the others to the specific contractors who are providing the services. Please review, complete, and submit your order forms as early as possible to take advantage of our discount pricing.

Please refer to the enclosed *Show Details* page for vital facts and information about this event. If you have any additional questions about Brede's services, please do not hesitate to call or email Brede's E-bike Challenge Customer Service Representative at sharon.sandvik@brede.com.

A Brede Service Desk will be maintained in the exhibit area during exhibitor move-in to answer any questions that arise and to assist with any last minute requirements.

We look forward to working with you and your company toward a successful show.

Thank you.

Brede

Brede

EXPOSITION SERVICES



Minneapolis Convention Center - Hall A
Minneapolis, MN
March 23-24, 2019

Brede Customer Service

- 612.378.6522 Fax 612.331.8380 e-mail: sharon.sandvik@brede.com
- Office Hours: 8:00 AM - 4:30 PM (central time)
- No telephone orders accepted; please complete and submit your order and credit card information to Brede.

Show Management

- Hicle Inc. PO Box 535, Julian, CA 92036
- 760.415.3801 (Constance Hughes, USA) +31 6 47 45 84 16 (Theo Jorna, Netherlands)
- info@E-bikechallenge.com

Booths

- **10' x 10' Inline Curtain Booth:** 10' of 8' high back drape + 20' of 3' side drape + carpet + booth ID sign
- **10' x 10' Corner Curtain Booth:** 10' of 8' high back drape + 10' of 3' side drape + carpet + booth ID sign
- **10' x 10' Corner Booth:** 6 panels of 8' high white hardwall + carpet + 2 meter ID sign (*customization not included*)
- **10' x 10' In-Line Booth:** 9 panels of 8' high white hardwall + carpet + 3 meter ID sign (*customization not included*)

Material Handling

Advance to Warehouse

Late to warehouse charges apply after: **March 15, 2019**

TO: Exhibiting Company Name and Booth #

FOR: E-bike Challenge

Brede Exposition Services

c/o YRC Freight

12400 Dupont Avenue South

Burnsville, MN 55337

Direct to Show Site

Do not deliver prior to: **March 21, 2019**

TO: Exhibiting Company Name and Booth #

FOR: E-bike Challenge

Brede Exposition Services

Minneapolis Convention Center - Hall A

1301 Second Avenue South

Minneapolis, MN 55403

Exhibitor Schedule

Exhibitor Move-in:	Thursday	March 21, 2019	7:00 AM	—	11:00 PM
	Friday	March 22, 2019	12:00 PM	—	11:00 PM
Show Hours:	Saturday	March 23, 2019	9:00 AM	—	5:00 PM
	Sunday	March 24, 2019	9:00 AM	—	5:00 PM
Exhibitor Move-out:	Sunday	March 24, 2019	6:00 PM	—	8:00 PM

- Drivers for all carriers must be checked in at the Brede Service Desk for pick-up of freight by: **6:00 PM on Sunday, March 24, 2019.**

Utilities & Services

- For booth utilities and additional booth services, please contact the individual suppliers using the enclosed order forms.



[Find more on Brede.com](http://Brede.com)



phone 612.331.4540

fax 612.331.8380

e-mail sharon.sandvik@brede.com



Information Form Please make your show site representative aware of the following policies.

Important Deadlines

- Take advantage of advance order discount pricing! Orders must be received with payment in full no later than the following dates. Orders received with payment in full after discount deadline dates will be invoiced at "standard floor" pricing.

Carpet and furnishings rentals **March 8, 2019**

Custom exhibits rentals **March 8, 2019**

Labor orders **March 8, 2019**

- Freight received at the warehouse after the deadline will incur an additional charge.

Advance shipments to warehouse to arrive by: **March 15, 2019**

Shipments to show site to arrive no sooner than: **March 21, 2019**

Payment Policies

- Orders received without full payment or credit card information will not be processed.
- A credit card on file is required when using Brede Exposition Services.
- All charges must be paid prior to close of show.
- For your convenience, we accept the following methods of payment: cash; checks and money orders drawn on U.S. banks in U.S. funds; and credit cards including VISA, MasterCard and American Express.
- Purchase Orders are not considered payment; therefore, a check or credit card is required.

Cancellations & Adjustments

- Cancellations are invoiced at 50% of original price, unless otherwise noted on order form.
- No adjustments will be made after close of the show.

Tax Exemption

- If tax exempt, a copy of your tax exempt certificate must accompany your order. This is not a resale certificate.
- No adjustments for tax exempt status will be made after close of the show.

Third Party Payment Billing

- The exhibiting company is ultimately responsible for the payment of all charges. If no arrangements are made for payment of invoice(s) by the third party prior to the last day of the show, charges will revert back to the exhibitor.

Miscellaneous

- Rental items not ordered, yet found in booths, are invoiced at "Standard Floor" pricing.
- All prices are in U.S. dollars (\$).
- All rental items are subject to applicable taxes.
- All rental items remain the property of Brede Exposition Services.



[Find more on Brede.com](http://www.brede.com)



phone 612.331.4540

fax 612.331.8380

e-mail sharon.sandvik@brede.com

Brede

EXPOSITION SERVICES



Minneapolis Convention Center - Hall A
Minneapolis, MN
March 23-24, 2019



Required Form

This form must accompany any completed order form(s) submitted to Brede.
Payment Method must be completed to process orders.
Orders received without full payment or credit card information will not be processed.

Advance Order Discount Deadline: March 8, 2019

Order Summary

Rental Booth Options	\$	_____
Add Some Graphics	\$	_____
Carpet Color for Curtain Booth	\$	_____
Carpet Padding & Custom Carpet	\$	_____
Tables & Accessories	\$	_____
Exhibits Plus	\$	_____
Material Handling	\$	_____
Labor	\$	_____
Forklift	\$	_____
Hanging Sign	\$	_____
Graphics	\$	_____
Total Due	\$	_____

Payment Method

- For your convenience, we accept cash, checks and money orders drawn on U.S. banks in U.S. funds, VISA, MasterCard and American Express. Third Party Payer
- Purchase Orders are not considered payment. MN Tax Exempt include ST3 Form
- All charges must be paid prior to close of show.
- Orders received without full payment or credit card information will not be processed. Our Federal ID # 41-0163660
- A credit card on file is required when using Brede Exposition Services.

Pay By Credit Card

- Please complete the *Credit Card Authorization* form and submit with your order.

Pay By Check or Money Order Payable to Brede Exposition Services

- International checks must be drawn on a U.S. bank, U.S. funds account only—processing fee of \$30.00.
- Please include **E-bike Challenge** and booth number on all payments.

Check Number _____ Dated _____ Amount _____

Exhibiting Company

Company: _____ Contact: _____
 Address: _____ City, State, Zip: _____
 Phone: _____ Fax: _____ Email: _____

Booth Number

COMPLETE and SUBMIT this form:

by mail Brede Exposition Services | 2211 Broadway St. NE | Minneapolis, MN 55413 | USA by fax 612.331.8380

Order Summary / Payment Method



Order Form

Submit this form if you wish to order options for your Rental Booth.
 Enter the Rental Booth Total below on Order Summary / Payment form.
 Orders received without full payment or credit card information will not be processed.

Advance Order Discount Deadline: March 8, 2019

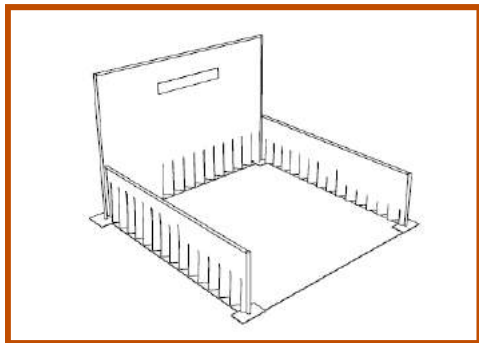

10' x 10' Inline Curtain Booth Includes:

- 10' of 8' back drape
- 20' of 3' side drape
- Carpet
- Header
- Labor to Install & Dismantle

Select Carpet Color: Black Blue Red Grey Pepper Forest Green

Header Copy ~ One line with block letters: _____

(Please print clearly. Logos, color, & special lettering available at an additional cost. Call for quote.) *Booth comes with*

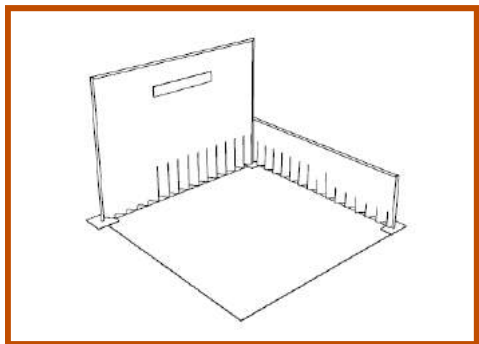

10' x 10' Corner Curtain Booth Includes:

- 10' of 8' back drape
- 20' of 3' side drape
- Carpet
- Header
- Labor to Install & Dismantle

Select Carpet Color: Black Blue Red Grey Pepper Forest Green

Header Copy ~ One line with block letters: _____

(Please print clearly. Logos, color, & special lettering available at an additional cost. Call for quote.) *Booth comes with a standard company name header.*

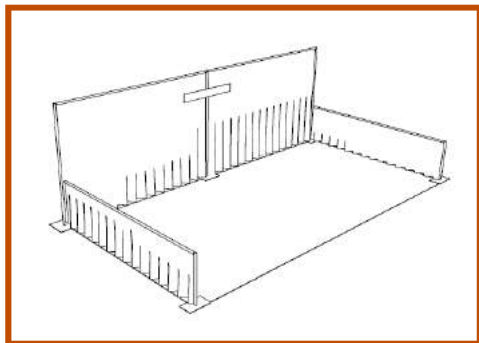

10' x 20' Inline Curtain Booth Expansion Includes:

- 8' back drape
- 3' side drape
- Carpet
- Header
- Labor to Install & Dismantle

Select Carpet Color: Black Blue Red Grey Pepper Forest Green

Header Copy ~ One line with block letters: _____

(Please print clearly. Logos, color, & special lettering available at an additional cost. Call for quote.) *Booth comes with*

Important Notes

- Electricity is not included with rental.
- Cancelled orders will be charged 100% of the original price.
- A credit card on file is required when using Brede Exposition Services.
- All charges must be paid prior to close of show.

Calculate

Subtotal \$ _____
 8.025% MN Tax \$ _____
Est. Total \$ _____

- Transfer this total to the *Order Summary / Payment* form.
- Payment Method must be completed to process orders.
- Orders received without full payment will not be processed.

Exhibiting Company _____

Booth Number

COMPLETE and SUBMIT this form:

by mail Brede Exposition Services | 2211 Broadway St. NE | Minneapolis, MN 55413 | USA by fax 612.331.8380



Order Form

Submit this form if you wish to order options for your Rental Booth.
 Enter the Rental Booth Total below on Order Summary / Payment form.
 Orders received without full payment or credit card information will not be processed.

Advance Order Discount Deadline: March 8, 2019

10' x 10' Corner Booth Option A Includes:

- White Panels • Carpet • Header • Labor to Install & Dismantle

Qty	Item	Subtotal
_____	Change to Velcro Compatible Panels <i>per 1M panel</i>	\$ 120.00 \$ _____
_____	Change to 8' Drape <i>per 10'</i>	\$ 170.00 \$ _____
_____	Add Graphics (see next page)	

10' x 10' Corner Booth Option B Includes:

- White Panels • Carpet • Header • Labor to Install & Dismantle

Qty	Item	Subtotal
_____	Change to Velcro Compatible Panels <i>per 1M panel</i>	\$ 120.00 \$ _____
_____	Change to 8' Drape <i>per 10'</i>	\$ 170.00 \$ _____
_____	Add Graphics (see next page)	

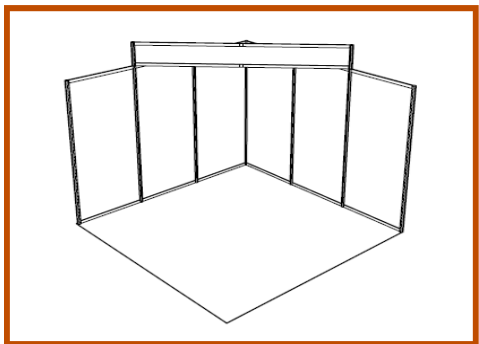
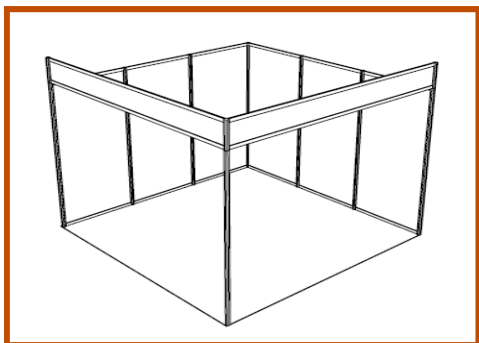

Color Options:

Select Carpet Color: Black Blue Red Grey Pepper Forest Green

Header Copy:

Header Copy ~ One line with block letters: _____
 (Please print clearly. Logos, color, & special lettering available at an additional cost. Call for quote.) *Booth comes with a standard company name header.*

Additional Options

Qty	Item	Advance	Standard	Subtotal
_____	Adjustable Shelves	\$ 42.25	\$ 54.75	\$ _____
_____	Spot Lights (use w/ rental only)	\$ 65.50	\$ 85.00	\$ _____
_____	1M curved or square counter (graphics on the front) Circle one: Curved or Square	\$ 400.00	\$ 520.00	\$ _____

Additional booth furnishings can be found throughout manual. Look for upgraded carpet, carpet pad, graphics, chairs, etc.

Important Notes

- Electricity is not included with rental.
- Cancelled orders will be charged 100% of the original price.
- A credit card on file is required when using Brede Exposition Services.
- All charges must be paid prior to close of show.

Calculate

Subtotal \$ _____
 8.025% MN Tax \$ _____
Est. Total \$ _____

- Transfer this total to the Order Summary / Payment form.
- Payment Method must be completed to process orders.
- Orders received without full payment will not be processed.

Exhibiting Company _____

Booth Number

COMPLETE and SUBMIT this form:

by mail Brede Exposition Services | 2211 Broadway St. NE | Minneapolis, MN 55413 | USA by fax 612.331.8380



Order Form

Submit this form to choose your Graphics.
Enter the total on Order Summary / Payment form.
Orders received without full payment or credit card information will not be processed.

Orders Must Be Received By: March 8, 2019

- All booths come with a standard, company name header.

10' x 10' Corner Booth A

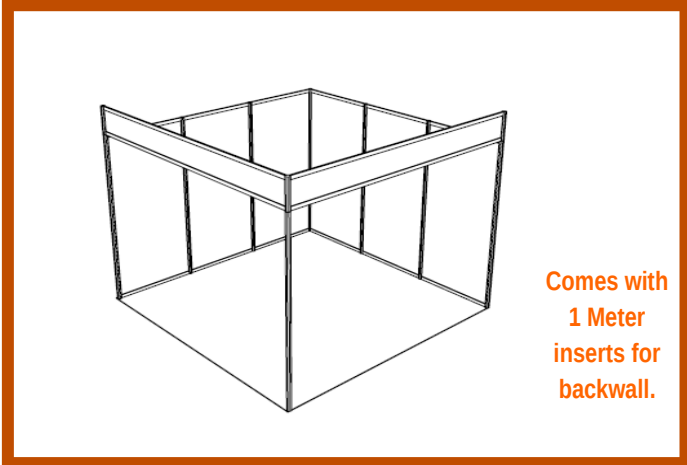

Comes with 1 Meter inserts for backwall.

ADD SOME CUSTOM GRAPHICS

	Qty	Advance
1M Graphic Inserts	_____	\$185.00
Header	_____	\$90.00
Option 1: 1 Piece Banner	_____	\$525.00
Option 2: 2 sections -1 or 2 piece	_____	\$592.00

- Graphics should be full size pdf's.
- Images should be no less than 100 dpi in the layouts.
- Logos should be line art pdf's or eps files.

10' x 10' Corner Booth B

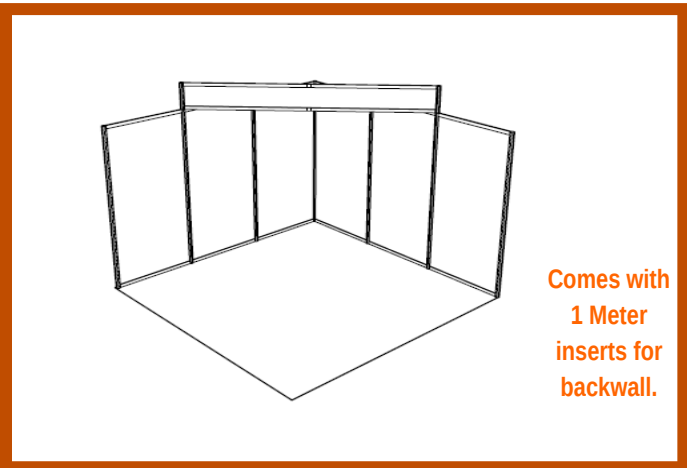

Comes with 1 Meter inserts for backwall.

ADD SOME CUSTOM GRAPHICS

	Qty	Advance
1M Graphic Inserts	_____	\$185.00
Header	_____	\$90.00
Option 1: 1 Piece Banner	_____	\$525.00
Option 2: 2 sections -1 or 2 piece	_____	\$592.00

- Graphics should be full size pdf's.
- Images should be no less than 100 dpi in the layouts.
- Logos should be line art pdf's or eps files.

Important Notes

- Orders cancelled prior to move-in will be charged 100% of the original price.
- A credit card on file is required when using Brede Exposition Services.
- All charges must be paid prior to close of show.

Calculate

Subtotal	\$	_____
8.025% MN Tax	\$	_____
Graphics Total	\$	_____

- Transfer this total to the Order Summary / Payment form.
- Payment Method must be completed to process orders.
- Orders received without full payment or credit card will not be processed.

Exhibiting Company _____

Booth Number

COMPLETE and SUBMIT this form:

by mail Brede Exposition Services | 2211 Broadway St. NE | Minneapolis, MN 55413 | USA by fax 612.331.8380



Order Form

Submit this form if you wish to order options for your Rental Booth.
 Enter the Rental Booth Total below on Order Summary / Payment form.
 Orders received without full payment or credit card information will not be processed.

Advance Order Discount Deadline: March 8, 2019

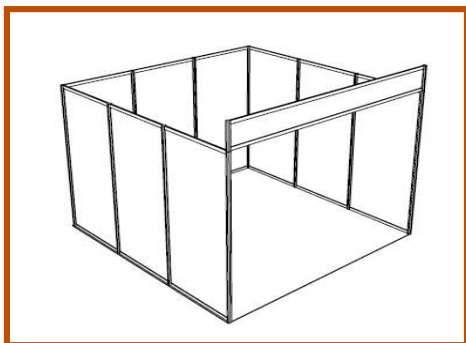

10' x 10' In-Line Booth A Includes:

- White Panels • Carpet • Header • Labor to Install & Dismantle

Qty	Item	Subtotal
_____	Change to Velcro Compatible Panels <i>per 1M panel</i>	\$ 120.00 \$ _____
_____	Change to 8' Drape <i>per 10'</i>	\$ 170.00 \$ _____
_____	Add Graphics (see next page)	

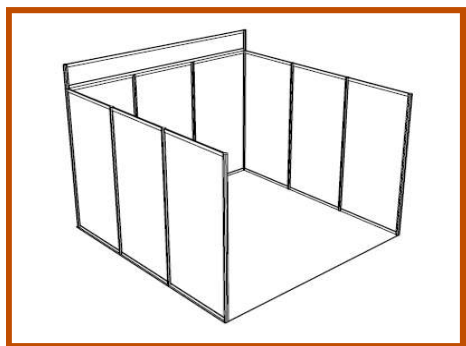

10' x 10' In-Line Booth B Includes:

- White Panels • Carpet • Header • Labor to Install & Dismantle

Qty	Item	Subtotal
_____	Change to Velcro Compatible Panels <i>per 1M panel</i>	\$ 120.00 \$ _____
_____	Change to 8' Drape <i>per 10'</i>	\$ 170.00 \$ _____
_____	Add Graphics (see next page)	

Color Options:

Select Carpet Color: Black Blue Red Grey Pepper Forest Green

Header Copy:

Header Copy ~ One line with block letters: _____
 (Please print clearly. Logos, color, & special lettering available at an additional cost. Call for quote.) *Booth comes with a standard company name header.*

Additional Options

Qty	Item	Advance	Standard	Subtotal
_____	Adjustable Shelves	\$ 42.25	\$ 54.75	\$ _____
_____	Spot Lights (use w/ rental only)	\$ 65.50	\$ 85.00	\$ _____
_____	1M curved or square counter (graphics on the front) <i>Circle one: Curved or Square</i>	\$ 400.00	\$ 520.00	\$ _____

Additional booth furnishings can be found throughout manual. Look for upgraded carpet, carpet pad, graphics, chairs, etc.

Important Notes

- Electricity is not included with rental.
- Cancelled orders will be charged 100% of the original price.
- A credit card on file is required when using Brede Exposition Services.
- All charges must be paid prior to close of show.

Calculate

Subtotal \$ _____
 8.025% MN Tax \$ _____
Est. Total \$ _____

- Transfer this total to the Order Summary / Payment form.
- Payment Method must be completed to process orders.
- Orders received without full payment will not be processed.

Exhibiting Company _____

Booth Number

COMPLETE and SUBMIT this form:

by mail Brede Exposition Services | 2211 Broadway St. NE | Minneapolis, MN 55413 | USA by fax 612.331.8380



Order Form

Submit this form to choose your Graphics.
 Enter the total on Order Summary / Payment form.
 Orders received without full payment or credit card information will not be processed.

Orders Must Be Received By: March 8, 2019

- All booths come with a standard, company name header.

10' x 10' In-Line Booth A

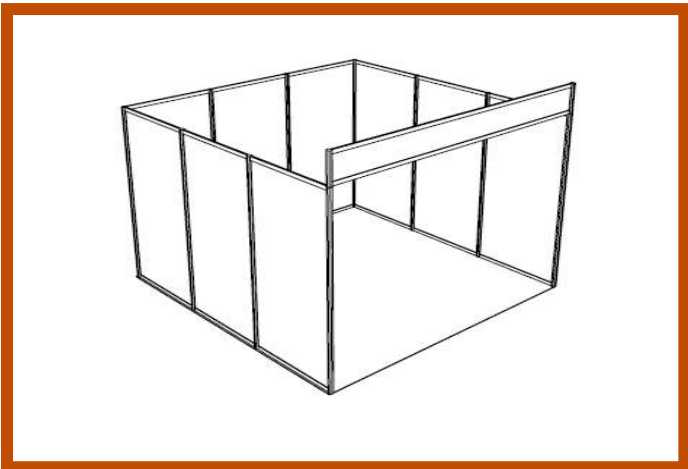

ADD SOME CUSTOM GRAPHICS

	Qty	Advance
1M Graphic Inserts	_____	\$185.00
Header	_____	\$90.00
Option 1: 1 Piece Banner 10' wide x 8' high	_____	\$525.00
Option 2: 2 sections -1 or 2 piece 5' wide x 8' high	_____	\$592.00

- Graphics should be full size pdf's.
- Images should be no less than 100 dpi in the layouts.
- Logos should be line art pdf's or eps files.

10' x 10' In-Line Booth B

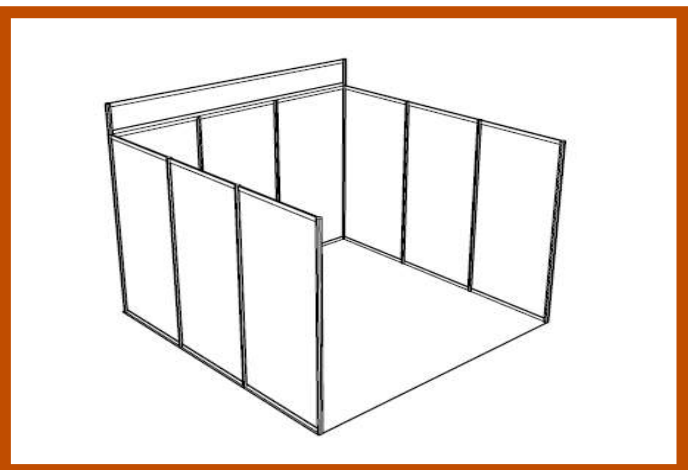

ADD SOME CUSTOM GRAPHICS

	Qty	Advance
1M Graphic Inserts	_____	\$185.00
Header	_____	\$90.00
Option 1: 1 Piece Banner 10' wide x 8' high	_____	\$525.00
Option 2: 2 sections -1 or 2 piece 5' wide x 8' high	_____	\$592.00

- Graphics should be full size pdf's.
- Images should be no less than 100 dpi in the layouts.
- Logos should be line art pdf's or eps files.

Important Notes

- Orders cancelled prior to move-in will be charged 100% of the original price.
- Orders cancelled after move-in begins will be charged 100% of the original price.
- A credit card on file is required when using Brede Exposition Services.
- All charges must be paid prior to close of show.

Calculate

Subtotal	\$	_____
8.025% MN Tax	\$	_____
Graphics Total	\$	_____

- Transfer this total to the Order Summary / Payment form.
- Payment Method must be completed to process orders.
- Orders received without full payment or credit card will not be processed.

Exhibiting Company _____

Booth Number

COMPLETE and SUBMIT this form:

by mail Brede Exposition Services | 2211 Broadway St. NE | Minneapolis, MN 55413 | USA by fax 612.331.8380



Order Form

Submit this form if you wish to order options for your Rental Booth.
 Enter the Rental Booth Total below on Order Summary / Payment form.
 Orders received without full payment or credit card information will not be processed.

Advance Order Discount Deadline: March 8, 2019

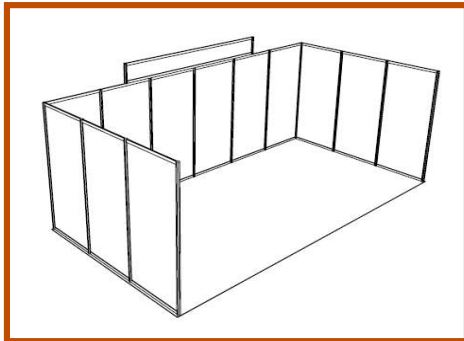

10' x 20' In-Line Booth Expansion:

- White Panels
- Carpet
- Header
- Labor to Install & Dismantle

Qty	Item	Subtotal
_____	Change to Velcro Compatible Panels <i>per 1M panel</i>	\$ 120.00 \$ _____
_____	Change to 8' Drape <i>per 10'</i>	\$ 170.00 \$ _____
_____	Add Graphics (see next page)	

Color Options:

Select Carpet Color: Black Blue Red Grey Pepper Forest Green

Header Copy:

Header Copy ~ One line with block letters: _____
 (Please print clearly. Logos, color, & special lettering available at an additional cost. Call for quote.) *Booth comes with a standard company name header.*

Additional Options

Qty	Item	Advance	Standard	Subtotal
_____	Adjustable Shelves	\$ 42.25	\$ 54.75	\$ _____
_____	Spot Lights (use w/ rental only)	\$ 65.50	\$ 85.00	\$ _____
_____	1M curved or square counter (graphics on the front) Circle one: Curved or Square	\$ 400.00	\$ 520.00	\$ _____

Additional booth furnishings can be found throughout manual. Look for upgraded carpet, carpet pad, graphics, chairs, etc.

Important Notes

- Electricity is not included with rental.
- Cancelled orders will be charged 100% of the original price.
- A credit card on file is required when using Brede Exposition Services.
- All charges must be paid prior to close of show.

Calculate

Subtotal \$ _____
 8.025% MN Tax \$ _____
Est. Total \$ _____

- Transfer this total to the Order Summary / Payment form.
- Payment Method must be completed to process orders.
- Orders received without full payment will not be processed.

Exhibiting Company _____

Booth Number

COMPLETE and SUBMIT this form:

by mail Brede Exposition Services | 2211 Broadway St. NE | Minneapolis, MN 55413 | USA by fax 612.331.8380



Order Form

Submit this form to choose your Graphics.
 Enter the total on Order Summary / Payment form.
 Orders received without full payment or credit card information will not be processed.

Orders Must Be Received By: March 8, 2019

- All booths come with a standard, company name header.

10' x 20' In-Line Booth Expansion

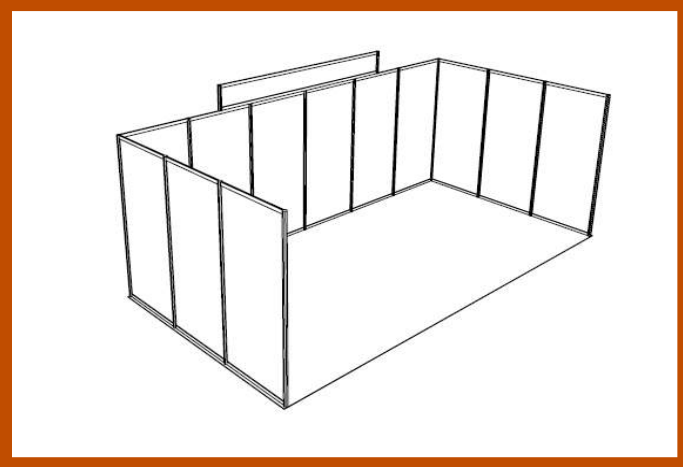

ADD SOME CUSTOM GRAPHICS

	Qty	Advance
1M Graphic Inserts	_____	\$185.00
Header	_____	\$90.00
Option 1: 1 Piece Banner 10' wide x 8' high	_____	\$525.00
Option 2: 2 sections -1 or 2 piece 5' wide x 8' high	_____	\$592.00

- Graphics should be full size pdf's.
- Images should be no less than 100 dpi in the layouts.
- Logos should be line art pdf's or eps files.

- Graphics should be full size pdf's.
- Images should be no less than 100 dpi in the layouts.
- Logos should be line art pdf's or eps files.

Important Notes

- Orders cancelled prior to move-in will be charged 100% of the original price.
- Orders cancelled after move-in begins will be charged 100% of the original price.
- A credit card on file is required when using Brede Exposition Services.
- All charges must be paid prior to close of show.

Calculate

Subtotal	\$	_____
8.025% MN Tax	\$	_____
Graphics Total	\$	_____

- Transfer this total to the *Order Summary / Payment* form.
- Payment Method must be completed to process orders.
- Orders received without full payment or credit card will not be processed.

Exhibiting Company _____

Booth Number

COMPLETE and SUBMIT this form:

by mail Brede Exposition Services | 2211 Broadway St. NE | Minneapolis, MN 55413 | USA by fax 612.331.8380



Order Form

Submit this form if you wish to order options for your Rental Booth.
 Enter the Rental Booth Total below on Order Summary / Payment form.
 Orders received without full payment or credit card information will not be processed.

Advance Order Discount Deadline: March 8, 2019

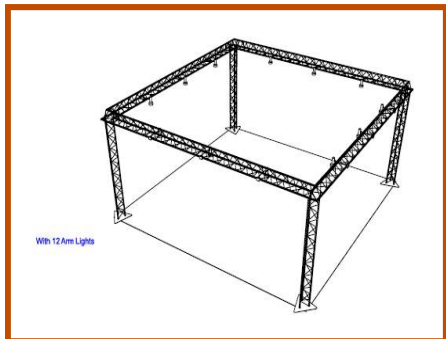

20' x 20' Truss Booth Includes:

- Truss
- Carpet
- (4) Lights
- Labor to Install & Dismantle

Qty	Item	Subtotal
_____	Add Lights	each \$ 65.50 \$ _____
_____	Add Graphics (see next page)	_____

Color Options:

Select Carpet Color: Black Blue Red Grey Pepper Forest Green

Header Copy:

Header Copy ~ One line with block letters: _____

- Graphics should be full size pdf's
- Images should be no less than 100 dpi in layouts
- Logos should be line art pdf's or eps files

Additional Options

Qty	Item	Advance	Standard	Subtotal
_____	Spot Lights (use w/ rental only)	\$ 65.50	\$ 85.00	\$ _____
_____	1M curved or square counter (graphics on the front) Circle one: Curved or Square	\$ 400.00	\$ 520.00	\$ _____

Additional booth furnishings can be found throughout manual. Look for upgraded carpet, carpet pad, graphics, chairs, etc.

Important Notes

- Electricity is not included with rental.
- Cancelled orders will be charged 100% of the original price.
- A credit card on file is required when using Brede Exposition Services.
- All charges must be paid prior to close of show.

Calculate

Subtotal \$ _____
 8.025% MN Tax \$ _____
Est. Total \$ _____

- Transfer this total to the Order Summary / Payment form.
- Payment Method must be completed to process orders.
- Orders received without full payment will not be processed.

Exhibiting Company _____

Booth Number

COMPLETE and SUBMIT this form:

by mail Brede Exposition Services | 2211 Broadway St. NE | Minneapolis, MN 55413 | USA by fax 612.331.8380



Order Form

Submit this form to choose your Graphics.
 Enter the total on Order Summary / Payment form.
 Orders received without full payment or credit card information will not be processed.

Orders Must Be Received By: March 8, 2019

- All booths come with a standard, company name header.

20' x 20' Truss Booth

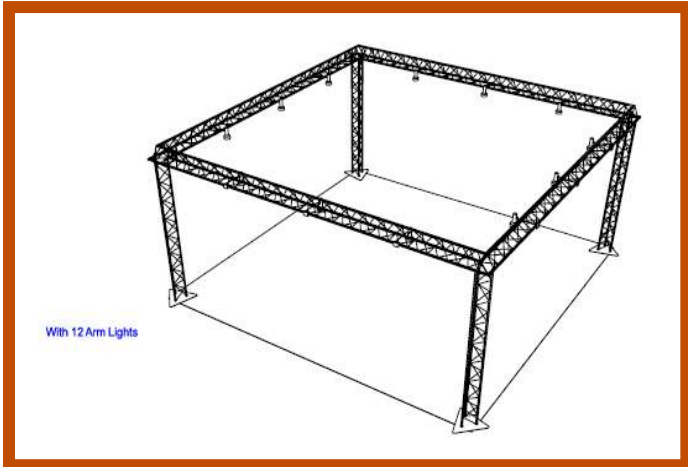

ADD SOME CUSTOM GRAPHICS

	Qty	Advance
Header	_____	\$120.00

- Graphics should be full size pdf's.
- Images should be no less than 100 dpi in the layouts.
- Logos should be line art pdf's or eps files.

Important Notes

- Orders cancelled prior to move-in will be charged 100% of the original price.
- Orders cancelled after move-in begins will be charged 100% of the original price.
- A credit card on file is required when using Brede Exposition Services.
- All charges must be paid prior to close of show.

Calculate

Subtotal	\$ _____
8.025% MN Tax	\$ _____
Graphics Total	\$ _____

- Transfer this total to the *Order Summary / Payment* form.
- Payment Method must be completed to process orders.
- Orders received without full payment or credit card will not be processed.

Exhibiting Company _____

Booth Number

COMPLETE and SUBMIT this form:

by mail Brede Exposition Services | 2211 Broadway St. NE | Minneapolis, MN 55413 | USA by fax 612.331.8380

Brede

EXPOSITION SERVICES

e-bike Challenge hicle

Minneapolis Convention Center - Hall A
Minneapolis, MN
March 23-24, 2019



Order Form

Submit this form if you wish to rent tables, risers or furnishings from Brede.
Enter the Table & Accessories Total below on Order Summary / Payment form.
Orders received without full payment or credit card information will not be processed.

Advance Order Discount Deadline: March 8, 2019



[Find more on Brede.com](#)

Tables

Qty	Item	Advance	Standard	Subtotal
30" High Display Tables (includes white vinyl top, 3 sided drape)				
_____	4' x 2' draped table	\$ 155.25	\$ 202.00	\$ _____
_____	6' x 2' draped table	\$ 176.25	\$ 229.00	\$ _____
_____	8' x 2' draped table	\$ 200.25	\$ 260.00	\$ _____
_____	4th side drape	\$ 77.00	\$ 100.25	\$ _____
_____	4' x 2' undraped table	\$ 68.25	\$ 89.00	\$ _____
_____	6' x 2' undraped table	\$ 73.00	\$ 94.25	\$ _____
_____	8' x 2' undraped table	\$ 77.75	\$ 101.50	\$ _____

42" High Display Tables (includes white vinyl top, 3 sided drape)				
_____	4' x 2' draped table	\$ 170.75	\$ 222.00	\$ _____
_____	6' x 2' draped table	\$ 190.50	\$ 247.25	\$ _____
_____	8' x 2' draped table	\$ 210.75	\$ 274.00	\$ _____
_____	4th side drape	\$ 77.00	\$ 100.25	\$ _____
_____	4' x 2' undraped table	\$ 73.50	\$ 95.75	\$ _____
_____	6' x 2' undraped table	\$ 79.25	\$ 103.25	\$ _____
_____	8' x 2' undraped table	\$ 85.50	\$ 111.00	\$ _____

12" Tabletop Risers (includes white vinyl top)				
_____	4' x 12" draped riser	\$ 78.75	\$ 102.00	\$ _____
_____	6' x 12" draped riser	\$ 90.00	\$ 116.75	\$ _____
_____	8' x 12" draped riser	\$ 134.00	\$ 174.00	\$ _____

Select Drape Color (if no color is selected, show colors will prevail.)

- | | | | | | | |
|--------------------------------|--------------------------------------|--------------------------------|---------------------------------|-----------------------------------|---------------------------------------|--------------------------------|
| <input type="checkbox"/> Beige | <input type="checkbox"/> Black | <input type="checkbox"/> Blue | <input type="checkbox"/> Brown | <input type="checkbox"/> Burgundy | <input type="checkbox"/> Forest Green | <input type="checkbox"/> Gold |
| <input type="checkbox"/> Grey | <input type="checkbox"/> Light Green | <input type="checkbox"/> Mauve | <input type="checkbox"/> Orange | <input type="checkbox"/> Red | <input type="checkbox"/> Teal | <input type="checkbox"/> White |

Accessories

Qty	Item	Advance	Standard	Subtotal
_____	Padded Side Chair - Grey	\$ 77.25	\$ 100.25	\$ _____
_____	Padded Arm Chair - Grey	\$ 91.50	\$ 119.25	\$ _____
_____	Upholstered Arm Chair - Grey	\$ 131.75	\$ 171.00	\$ _____
_____	Counter Stool with Back	\$ 142.25	\$ 185.75	\$ _____
_____	30" Pedestal Table-30" d	\$ 136.00	\$ 176.50	\$ _____
_____	42" Pedestal Table-30" d	\$ 157.25	\$ 205.00	\$ _____
_____	Coffee Table - 2' x 3'	\$ 106.00	\$ 125.25	\$ _____
_____	Waste basket	\$ 35.75	\$ 46.25	\$ _____
_____	Floor Easel	\$ 56.00	\$ 72.75	\$ _____
_____	Sign Stand 22" x 28"	\$ 121.50	\$ 158.25	\$ _____
_____	Coat Tree	\$ 52.50	\$ 68.50	\$ _____
_____	Bag Rack	\$ 81.00	\$ 105.00	\$ _____
_____	Waterfall Rack	\$ 128.50	\$ 167.00	\$ _____
_____	2' x 8' Gridwall - White	\$ 83.50	\$ 108.50	\$ _____
_____	Tackboard 8'x4' (horizontal only)	\$ 192.00	\$ 249.50	\$ _____
_____	Perfboard 8' x 4'			
	<input type="checkbox"/> horizontal <input type="checkbox"/> vertical	\$ 192.00	\$ 249.50	\$ _____
_____	Showcase	\$ 476.50	\$ 619.25	\$ _____
_____	3' high drapery (per ft)	\$ 24.75	\$ 31.25	\$ _____
_____	8' high drapery (per ft)	\$ 27.75	\$ 36.00	\$ _____

Important Notes

- Orders cancelled prior to move-in will be charged 50% of the original price.
- Orders cancelled after move-in begins will be charged 100% of the original price.
- A credit card on file is required when using Brede Exposition Services.
- All charges must be paid prior to close of show.

Calculate

Subtotal \$ _____
8.025% MN Tax \$ _____
Table Total \$ _____

- Transfer this total to the *Order Summary / Payment* form.
- Payment Method must be completed to process orders.
- Orders received without full payment or credit card will not be processed.

Exhibiting Company _____

Booth Number

COMPLETE and SUBMIT this form:

by mail Brede Exposition Services | 2211 Broadway St. NE | Minneapolis, MN 55413 | USA by fax 612.331.8380

Tables & Accessories



Order Form

Submit this form if you wish to purchase Specialty Items from Brede.
Enter the Banner Item Total below on Order Summary / Payment form.
Orders received without full payment or credit card information will not be processed.

Orders Must Be Received By: March 8, 2019

IMA Banner Stand

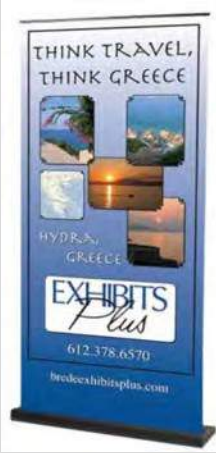

Description

- 31.5" wide single sided banner stand w/padded bag
- Standard Vinyl (anti-curl)
- Lifetime warranty on frame

Graphics Size

- 31.5" wide x 83.25" high

Banner Stand	Qty	Advance
31.5"w single sided banner stand w/padded bag	_____	\$356.00

Premium Dyesub Table Throw



Table Throw	Qty	Advance
48"w x 30"h x 24"d - draped on 3 sides	_____	\$206.00
48"w x 30"h x 24"d - draped on 4 sides	_____	\$284.00
72"w x 30"h x 24"d - draped on 3 sides	_____	\$296.00
72"w x 30"h x 24"d - draped on 4 sides	_____	\$371.00
96"w x 30"h x 24"d - draped on 3 sides	_____	\$318.00
96"w x 30"h x 24"d - draped on 4 sides	_____	\$442.00

Premium Dyesub Table Runner



Table Runner	Qty	Advance
30"w x 84"h - drapes over front, top and back	_____	\$130.00
60"w x 84"h - drapes over front, top and back	_____	\$255.00

Important Notes

- File for graphics should be pdf print ready at full size for all banner stands. For table runner, graphics should be Vector art file 300 DPI Adobe, Illustrator.
- Cancelled orders will be charged 100% of the original price.
- A credit card on file is required when using Brede.

Calculate

Subtotal \$ _____
8.025% MN Tax \$ _____
Banner Total \$ _____

- Transfer this total to the *Order Summary / Payment* form.
- Payment Method must be completed to process orders.
- Orders received without full payment or credit card will not

Exhibiting Company _____

Booth Number

COMPLETE and SUBMIT this form: Please call Colleen Brandt with questions at 612.378.6570

by mail Brede Exposition Services | 2211 Broadway St. NE | Minneapolis, MN 55413 | USA by fax 612.331.8380



Order Form

Submit this form if you wish to rent a 3 Tier Display Table from Brede.
 Enter the 3 Tier Display Table Total below on Order Summary / Payment form.
 Orders received without full payment or credit card information will not be processed.

Advance Order Discount Deadline: March 8, 2019

Rental

Qty	Description	Color	Special	Standard	Subtotal
	Display Table	<input type="checkbox"/> Black <input type="checkbox"/> White	\$ 185.00	\$ 198.00	\$ _____



Exhibits Plus 3 Tier Display Tables

Dimensions

- 48" high.
- 17" across top tier
- 24" across middle tier
- 32" across bottom tier

Important Notes

- Orders cancelled prior to move-in will be charged 50% of the original price.
- Orders cancelled after move-in begins will be charged 100% of the original price.
- A credit card on file is required when using Brede Exposition Services.
- All charges must be paid prior to close of show.

Calculate

Subtotal \$ _____
 8.025% MN Tax \$ _____
Est. Total \$ _____

- Transfer this total to the *Order Summary / Payment* form.
- Payment Method must be completed to process orders.
- Orders received without full payment or credit card will not be processed.

Exhibiting Company _____

Booth Number

COMPLETE and SUBMIT this form: Please call Colleen Brandt with questions at 612.378.6570

by mail Brede Exposition Services | 2211 Broadway St. NE | Minneapolis, MN 55413 | USA by fax 612.331.8380

Brede

EXPOSITION SERVICES



Minneapolis Convention Center - Hall A
Minneapolis, MN
March 23-24, 2019



Order Form

Submit this form if you wish to rent a modular unit from Brede.
Enter the Modular Unit Total below on Order Summary / Payment form.
Orders received without full payment or credit card information will not be processed.

Advance Order Discount Deadline: March 8, 2019

Qty	Description	Advance	Standard	TOTAL
	FS Table-Top with header panel & 2 lights			
_____	A Panel: 7' wide x 3' high / Header Panel: 7' wide x 4' high	\$ 406.00	\$ 468.00	\$ _____
_____	B HP-20 Unit with lights and tables: 20' wide x 8' high	\$ 2,500.00	\$ 2,812.00	\$ _____
_____	C S-10 with 6' backlit header panel: 10' wide x 8' high	\$ 700.00	\$ 875.00	\$ _____
_____	D Gridwall: 10' wide x 8' high	\$ 825.00	\$ 975.00	\$ _____
_____	E PS-1 Unit: 10' wide x 8' high	\$ 725.00	\$ 906.00	\$ _____
_____	F Abex Unit-Curved display with lights: 10' wide x 8' high	\$ 815.00	\$ 975.00	\$ _____
_____	Full Lexan Sign: 14.5" x 148.5" / Image Area: 117.5"	\$ 386.00	\$ 478.00	\$ _____
_____	G Bay Unit with lights: 10' wide x 8' high	\$ 850.00	\$ 965.00	\$ _____
_____	H HP-1 Unit with lights: 10' wide x 8' high	\$ 800.00	\$ 935.00	\$ _____
_____	I VP-1 Unit with lights: 10' wide x 8' high	\$ 825.00	\$ 975.00	\$ _____
_____	Sintra Sign for VP-1 Unit: 12" x 48"	\$ 145.00	\$ 187.00	\$ _____
_____	J FS-3 Panel Folding Stackables: 7' wide x 7' high	\$ 569.00	\$ 640.00	\$ _____
_____	Sign with Company Name: 12" x 28"	\$ 92.00	\$ 119.50	\$ _____
_____	End Panel: 27.5" wide / Header Panel: 12" high / Middle Panel: 28" wide			
_____	K Black Triangular Tower: 27.5" wide x 7' high	\$ 546.00	\$ 639.00	\$ _____
_____	Modular Tables			
_____	L <input type="checkbox"/> Rectangular 3' wide x 3' high x 20" <input type="checkbox"/> Trapezoidal: 4' wide x 3' high x 20"	\$ 156.00	\$ 193.25	\$ _____
_____	1 shelf & sliding door option	\$ 265.00	\$ 321.00	\$ _____
_____	M-1 Triangular Tiered Pedestals: 28" wide x 36" high	\$ 150.00	\$ 193.00	\$ _____
_____	M-2 Triangular Tiered Pedestals: 21" wide x 24" high	\$ 135.00	\$ 173.00	\$ _____
_____	M-3 Triangular Tiered Pedestals: 28" wide x 12" high	\$ 98.00	\$ 126.00	\$ _____
_____	Velcro Panel 4' x 8': <input type="checkbox"/> Horizontal <input type="checkbox"/> Vertical	\$ 125.00	\$ 157.00	\$ _____
_____	10" deep shelf with brackets	\$ 27.00	\$ 35.00	\$ _____
_____	Brochure holder with Velcro: <input type="checkbox"/> 9" x 11" <input type="checkbox"/> 4" x 7"	\$ 18.50	\$ 24.00	\$ _____
_____	15' roll Velcro	\$ 67.00	\$ 87.00	\$ _____

Important Notes

- Electricity is not included with rental.
- Cancelled orders will be charged 100% of the original price.
- A credit card on file is required when using Brede Exposition Services.
- All charges must be paid prior to close of show.
- Orders received less than 14 days prior to move-in are subject to availability.

Calculate

Subtotal \$ _____
8.025% MN Tax \$ _____
Est. Total \$ _____

- Transfer this total to the *Order Summary / Payment* form.
- Payment Method must be completed to process orders.
- Orders received without full payment or credit card will not be processed.

Exhibiting Company _____

Booth Number

COMPLETE and SUBMIT this form: Please call Colleen Brandt with questions at 612.378.6570

by mail Brede Exposition Services | 2211 Broadway St. NE | Minneapolis, MN 55413 | USA by fax 612.331.8380

Exhibits Plus Modular Units

Brede

EXPOSITION SERVICES

e-bike Challenge hicle

Minneapolis Convention Center - Hall A
Minneapolis, MN
March 23-24, 2019



Order Form

Submit this form if you wish to rent a custom furniture from Brede.
Please contact Brede if you would like to inquire about our Custom Furniture.
Enter the Custom Furniture Total below on Order Summary / Payment form.
Orders received without full payment or credit card information will not be processed.

Advance Order Discount Deadline: March 8, 2019

Qty	Description	Advance	Standard	Subtotal	Qty	Description	Advance	Standard	Subtotal
___	A-1 Sled base guest chair, black frame, black fabric seat, 23"w x 24"d x 34"h	\$ 89.00	\$ 111.25	\$	___	H-1 Black leather club chair 33"w x 32"d x 33"h	\$ 268.00	\$ 332.00	\$
___	A-2 Black round table: 36"d x 30"h	\$ 96.00	\$ 119.00	\$	___	H-2 Black leather love seat 56"w x 32"d x 33"h	\$ 293.00	\$ 363.00	\$
___	B-1 Leather side chair-black 24"w x 27.5"d x 35"h	\$ 127.00	\$ 157.00	\$	___	H-3 Black leather sofa 79"w x 32"d x 33"h	\$ 383.00	\$ 474.00	\$
___	B-2 Conference table-X base-cherry wood 47"d x30"h	\$ 135.00	\$ 168.75	\$	___	H-4 End table-mahogany 24"w x 24"d x 20"h	\$ 124.00	\$ 155.00	\$
___	C-1 Loveseat-White 52.5"w x 29"d x 30"h	\$ 293.00	\$ 363.00	\$	___	H-5 Coffee tbl.-mahogany 48"w x20"d x16"h	\$ 124.00	\$ 155.00	\$
___	C-2 Sofa-White 72.5"w x 29"d x 30"h	\$ 383.00	\$ 474.00	\$	___	I-1 Black literature rack 18"w x 59"h	\$ 106.00	\$ 132.00	\$
___	C-3 Chair-White 32"w x 29"d x 30"h	\$ 268.00	\$ 332.00	\$	___	I-2 Black jazz literature rack 13"w x 54"h	\$ 106.00	\$ 132.00	\$
___	D-1 Bar Stool-black-chrome base 15.1"w x 15.1"d x 25.2"-30.8"h	\$ 93.00	\$ 112.00	\$	___	I-3 Plex literature rack 10"w x 53"h	\$ 106.00	\$ 132.00	\$
___	D-2 Director chair-black canvas-natural wood 23"w x 16"d x 36"h	\$ 68.00	\$ 85.00	\$	___	I-4 Black mesh literature rack 19.5"w x 54"h	\$ 106.00	\$ 132.00	\$
___	D-3 Director stool-black canvas-natural wood 23"w x 16"d x 48"h	\$ 76.00	\$ 95.00	\$					
___	E-1 Cylinder-solid grey: 30"d x 21"h	\$ 117.00	\$ 146.00	\$					
___	E-2 Tall pedestal-grey 12"w x 12"d x 36"h	\$ 85.50	\$ 107.00	\$					
___	E-3 Small cube-grey 24"w x 24"d x 21"h	\$ 82.00	\$ 103.00	\$					
___	F-1 Tall pedestal table-black laminate top Black base 30"d x 41.75"h	\$ 97.50	\$ 120.00	\$					
___	F-2 Bar stools 20"w x 20"d x 30.5"h	\$ 94.00	\$ 114.00	\$					
___	G-1 Conference table - cherry wood laminate black base 47"d x 29"h	\$ 135.00	\$ 168.75	\$					
___	G-2 Leather side chair-black 24"wx27"dx35"h	\$ 127.00	\$ 157.00	\$					
___	G-3 Pedestal-black 20"w x 20"d x 48"h	\$ 185.00	\$ 231.00	\$					
___	G-4 Small black pedestal with brass trim 14.5"w x 14.5"d x 30"h	\$ 100.00	\$ 125.00	\$					

Important Notes

- All furniture are on a rental basis.
- Orders cancelled to move-in are subject to a 50% cancellation charge.
- Orders cancelled after move-in begins are subject to a 100% cancellation charge.
- On-site orders are subject to availability and are subject to an additional 50% late charge.

Calculate

Subtotal \$ _____
8.025% MN Tax \$ _____
Est. Total \$ _____

- Transfer this total to the *Order Summary / Payment* form.
- Payment Method must be completed to process orders.
- Orders received without full payment or credit card will not be processed.

Booth Number

Exhibiting Company _____

COMPLETE and SUBMIT this form: Please call Colleen Brandt with questions at 612.378.6570

by mail Brede Exposition Services | 2211 Broadway St. NE | Minneapolis, MN 55413 | USA by fax 612.331.8380

Exhibits Plus Custom Furniture

Brede

EXPOSITION SERVICES

e-bike Challenge hicle

Minneapolis Convention Center - Hall A
 Minneapolis, MN
 March 23-24, 2019



Order Form

Submit this form if you wish to rent silks from Brede.
 Enter the Silks Total below on Order Summary / Payment form.
 Orders received without full payment or credit card information will not be processed.

Advance Order Discount Deadline: March 8, 2019

Qty	Description	Advance	Standard	Subtotal
_____	A Spathyfillum Bush	\$ 28.50	\$ 37.00	\$ _____
_____	B Fountain Palm	\$ 33.00	\$ 43.00	\$ _____
_____	C Azalea Bush Hot Pink	\$ 33.00	\$ 43.00	\$ _____
_____	D Geranium Bush Red	\$ 29.50	\$ 38.25	\$ _____
_____	E Dieffenbachia	\$ 27.00	\$ 35.00	\$ _____
_____	F Japanese Mum Bush Yellow	\$ 27.00	\$ 35.00	\$ _____
_____	G Ficus Tree	\$ 81.50	\$ 105.50	\$ _____
_____	H Ruffle Fern	\$ 23.50	\$ 30.50	\$ _____

Important Notes

- Orders cancelled prior to move-in will be charged 50% of the original price.
- Orders cancelled after move-in begins will be charged 100% of the original price.
- A credit card on file is required when using Brede Exposition Services.
- All charges must be paid prior to close of show.

Calculate

Subtotal \$ _____
 8.025% MN Tax \$ _____
Est. Total \$ _____

- Transfer this total to the *Order Summary / Payment* form.
- Payment Method must be completed to process orders.
- Orders received without full payment or credit card will not be processed.

Exhibiting Company _____

Booth Number

COMPLETE and SUBMIT this form: Please call Colleen Brandt with questions at 612.378.6570

by mail Brede Exposition Services | 2211 Broadway St. NE | Minneapolis, MN 55413 | USA by fax 612.331.8380

Exhibits Plus Silks



Information Form

Brede Exposition Services' liability shall be limited to the physical loss or damage to the specific article which is lost or damaged as described below. Please make your show site representative aware of the following policy.

Limitations of Brede Exposition Services' Liability and Responsibility

1. Brede Exposition Services shall not be responsible for damage to uncrated materials, materials improperly packed, or concealed damage.
2. Brede Exposition Services shall not be responsible for loss, theft, or disappearance of exhibitor's materials after same have been delivered to exhibitor's booth.
3. Brede Exposition Services shall not be responsible for loss, theft, or disappearance of materials before they are picked up from exhibitor's booth for re-loading after the show. Brede bills of lading covering outgoing shipments which are tendered to Brede Exposition Services by exhibitors, will be checked at time of actual pickup from booth and corrections made where discrepancies occur.
4. Brede Exposition Services shall not be liable to any extent whatsoever for any actual, potential, or assumed loss of profits or revenues, or for any collateral costs, which may result from any loss or damage to an exhibitor's material which make it impossible or impractical to exhibit same.
5. The consignment or delivery of a shipment to Brede Exposition Services by an exhibitor, or by any shipper on behalf of any exhibitor shall be construed as an acceptance by such exhibitor (and/or other shipper) of the terms and conditions set forth in this bulletin.
6. Brede Exposition Services shall exercise ordinary diligence and care in the receiving, handling and storage of all shipments. Brede Exposition Services shall not be liable for loss or damage by fire, acts of God, or causes beyond its control. Brede Exposition Service's liability shall be limited to the physical loss or damage to the specific article which is lost or damaged. In any case, the liability of Brede Exposition Services is limited to \$.30 per pound per article, with a maximum of \$50.00 per item, and a maximum of \$1,000.00 per shipment. This applies while these goods are in Brede's warehouse, in vehicles for delivery, or at show site.
7. Claims for loss or damage which are not submitted to Brede Exposition Services within thirty (30) days of the close of the show on which the loss or damage occurred shall be considered waived. No suit or action shall be brought against Brede Exposition Services or its subcontractors more than one (1) year after the accrual of the cause of action therefore.
8. Shipments received without receipts, freight bills, or specified unit counts on receipts or freight bills (i.e., one lot, 800 cu. ft., etc.), such as UPS or van lines will be delivered to the exhibitor's booth without guarantee of piece count or condition. No liability will be assumed by Brede Exposition Services for such shipments.
9. Empty container labels will be available at the service desk. Affixing the labels is the sole responsibility of the exhibitor or his/her representative. All previous labels should be removed or completely covered. Brede Exposition Services assumes no responsibility for errors to the aforementioned procedure, removal of containers with old empty labels and without Brede Exposition Services labels, improper information on empty labels, or valuables stored in containers with empty labels.
10. Exhibitors should arrange for outgoing shipments during the show or immediately after its close. Brede will assist in the preparation of Brede bills of lading. Be sure that your material has been carefully crated or packed, and properly tagged or marked.
11. In order to expedite removal of materials, Brede Exposition Services shall have authority, without further clearance with exhibitors, to change designated carriers.
12. Labor and services ordered on behalf of exhibitors by display builders or other parties must be so authorized in a letter from exhibitors. Payment for all labor and services will be the responsibility of the exhibitor.
13. Freight handling charges are the responsibility of the exhibitor to whom shipments have been consigned. Also, charges for loading out freight shipments are the responsibility of the exhibitor from whose booth shipments are made. Exhibitors may not assign this responsibility to suppliers or customers.

The exhibitor agrees, in the event of a dispute with Brede Exposition Services relative to any loss or damage to any of their materials or equipment, that they will not withhold payment of any amount due to Brede Exposition Services for Drayage or any other services provided by Brede Exposition Services as an offset against the amount of the alleged loss or damage. Instead, they agree to pay Brede Exposition Services at the close of the show for all such charges, and they further agree that any claim they may have against Brede Exposition Services shall be pursued independently by them as a completely separate transaction to be resolved on its own merits.
14. Service charge of 1-1/2% per month on any unpaid balance will be made starting 30 days after date of invoice.
15. Where an exhibitor indicates choice of carrier for pickup it is the exhibitor's responsibility to arrange with such carrier for said pickup service. If the carrier does not pick up within the time limited for the removal of exhibitor's materials at the Exhibit Hall, we reserve the right to forward such material by the shipping method of our choice or to remove said material to our warehouse for disposition, at an additional charge to the exhibitor in accordance with prevailing rates for the service performed.
16. Material left behind without orders placed at the Drayage Service Desk may be classified as abandoned. The Drayage Contractor shall not be responsible for same. We are not responsible for any delay of rush shipments. We will expedite such rush shipments to the best of our ability, but will not assume any financial responsibility for shipments which do not arrive at their destination at a dated time.
17. **EXHIBITORS ARE URGED TO CARRY ALL-RISK INSURANCE** covering your materials against damage, loss and all other hazards from the time shipments are made prior to the show until shipments are received back after the show. This can generally be done by adding "riders" to existing insurance policies, often at no additional cost. It is understood that Brede Exposition Services is not an insurer, that insurance, if any, shall be obtained by the exhibitor and the amounts payable to Brede Exposition Services hereunder are based on the value of the material handling services and the scope of Brede Exposition Services liability as set forth above.



[Find more on Brede.com](http://Brede.com)



phone 612.331.4540

fax 612.331.8380

e-mail sharon.sandvik@brede.com



Information Form

Brede Exposition Services will receive your materials shipped in advance at our local warehouse, or shipped directly to show site. For detailed information regarding material handling services provided by Brede and the associated charges, please see below. Please make your show site representative aware of the following information.

Exhibitors may choose to ship freight to the advance warehouse or directly to show site. Brede will receive and manage the freight at the warehouse and on show site as described in the following pages. Material handling fees are paid to Brede for these material handling services, and are separate from and independent of freight transportation charges, which are paid to a freight carrier such as YRC, ABF, FedEx, or any other carrier of the exhibitor's choosing. Exhibitors are responsible for securing a carrier of their choosing and arranging freight transportation to and from the event, and all associated transportation fees.

Advance Shipments to the Warehouse

Deadlines and Info

- Receiving begins **30 days prior to exhibitor move-in.**
- Shipments received at the warehouse after **March 15, 2019** are subject to additional charges.
- Ship pre-paid; collect shipments will be refused
- Uncrated, pad wrapped or specialized equipment will not be accepted at the warehouse.
- Hazardous materials will not be accepted at the warehouse.

Advantages

There are several advantages to shipping advance to the warehouse versus directly to the show site:

- Exhibitors can confirm shipment has arrived and is intact in advance of the move-in date.
- Materials will be delivered to your booth prior to your arrival on site.
- Delivery dates and times are more flexible.

Advance Warehouse Rates

See below for definitions and descriptions of warehouse rates, and the *Material Handling Rates* form for the associated fees.

All material handling fees are calculated on a CWT basis (per hundredweight, or fraction thereof) per shipment, and vary depending on the type of shipment, the amount of handling and the time of day. Separate shipments will not be combined. Minimum charges will apply as shown on the *Material Handling Rates* form. Be sure to review these costs when you prepare your show budget. Contact Brede for assistance in estimating your material handling charges, based upon your specific needs.

Rates Include

Warehouse material handling rates include the following:

- Receiving exhibitor shipment at the advance warehouse, and storage beginning 30 days prior to the show.
- Movement of all exhibitor freight from warehouse to exhibit site.
- Materials unloaded and delivered to booth by move-in time.
- Pick-up and storing of shipping containers and boxes labeled EMPTY, and returning empty shipping containers to your booth at the close of the show. Empty labels may be obtained at the Brede Service Desk on show site. Empty containers are not accessible during the show.
- Removal of freight from booth, and reloading onto exhibitor's designated outbound carrier from the loading dock.

Crated or Skidded

Use this rate for shipments that arrive via common carrier such as YRC Freight, ABF, etc., and can be unloaded at the dock with no additional handling required. Material that is skidded or is in any type of shipping container that can be unloaded at the dock with no additional handling required.

Special Handling

Use this rate for shipments that are crated van line shipments or packed in such a manner as to require special handling, such as ground loading, side door loading, constricted space loading and designated piece loading or stacked shipments. Also included are mixed shipments without certified weight tickets or delivery receipts, such as Fedex, UPS, POVs (personally owned vehicles).

Small Package

Use this rate for cartons/envelopes weighing less than 25 lbs. per shipment without documentation. These will be delivered to the booth without guarantee of piece count or condition.



[Find more on Brede.com](http://www.brede.com)



phone 612.331.4540

fax 612.331.8380

e-mail sharon.sandvik@brede.com



Information Form

Brede Exposition Services will receive your materials shipped in advance at our local warehouse, or shipped directly to show site. For detailed information regarding material handling services provided by Brede and the associated charges, please see below. Please make your show site representative aware of the following information.

Direct Shipments to Show Site

Deadlines and Info

- Do not ship to the facility prior to **March 21, 2019**. Early shipments to show site may be refused. Brede Exposition Services will be on show site at the loading dock to receive exhibitor materials only during move-in hours.
- Ship pre-paid; collect shipments will be refused.
- Hazardous materials will not be accepted at show site.

Direct to Show Site Rates

See below for definitions and descriptions of direct to show site rates, and the *Material Handling Rates* form for the associated fees.

All material handling fees are calculated on a CWT basis (per hundredweight, or fraction thereof) per shipment, and vary depending on the type of shipment, the amount of handling and the time of day. Separate shipments will not be combined. Minimum charges will apply as shown on the *Material Handling Rates* form. Be sure to review these costs when you prepare your show budget. Contact Brede for assistance in estimating your material handling charges, based upon your specific needs.

Rates Include

Direct to show site material handling rates include the following:

- Materials unloaded at loading dock and delivered to booth.
- Pick-up and storing of shipping containers and boxes labeled EMPTY, and returning empty shipping containers to your booth at the close of the show. Empty labels may be obtained at the Brede Service Desk on show site. Empty containers are not accessible during the show.
- Removal of freight from booth, and reloading onto exhibitor's designated outbound carrier from the loading dock.

Crated or Skidded

Use this rate for shipments that arrive via common carrier such as YRC Freight, ABF, etc., and can be unloaded at the dock with no additional handling required. Material that is skidded or is in any type of shipping container that can be unloaded at the dock with no additional handling required.

Special Handling

Use this rate for shipments that are crated van line shipments or packed in such a manner as to require special handling, such as ground loading, side door loading, constricted space loading and designated piece loading or stacked shipments. Also included are mixed shipments without certified weight tickets or delivery receipts, such as Fedex, UPS, POVs (personally owned vehicles).

Uncrated, Unskidded, or Wrapped

Use this rate for shipments that are not in crates, cases, or boxes and/or pad wrapped, specialized equipment, unskidded machinery or uncrated POV shipments. Uncrated shipments are received at show site only.

Small Package

Use this rate for cartons/envelopes weighing less than 25 lbs. per shipment without documentation. Will be delivered to booth without guarantee of piece count or condition.

Overtime Charges

Inbound

Overtime charges apply on inbound shipments if:

- Your shipment is to be delivered to your booth before 8:00 am or after 4:00 pm on weekdays, or anytime on a Saturday, Sunday and/or Holiday, or
- Your shipment is received at the warehouse, and is delivered to show site before 8:00 am or after 4:00 pm on weekdays, or anytime on a Saturday, Sunday and/or Holiday, or
- A vehicle driver checks in at the Exhibit Site Check-In Area after 3:00 pm on weekdays, or anytime on a Saturday, Sunday and/or Holiday.

Outbound

Overtime charges apply on outbound shipments if:

- Your shipment is loaded after 4:00 pm on weekdays, or anytime on a Saturday, Sunday and/or Holiday, or
- Your carrier driver checks in at the Exhibit Site Check-In Area after 3:00 pm on weekdays, or anytime on a Saturday, Sunday and/or Holiday.



[Find more on Brede.com](http://Brede.com)



phone 612.331.4540

fax 612.331.8380

e-mail sharon.sandvik@brede.com



Information Form

Brede Exposition Services will receive your materials shipped in advance at our local warehouse, or shipped directly to show site. For detailed information regarding material handling services provided by Brede and the associated charges, please see below. Please make your show site representative aware of the following information.

Material Handling Documentation

Inbound Bill of Lading

All inbound shipments must have a Bill of Lading or delivery slip showing the number of pieces, type of merchandise and weight. Shipments received without this information will be delivered to exhibitor's booth without guarantee of piece count or condition. No liability will be assumed by Brede for such shipments. Billed weight is based on incoming weight, whether outbound services are used completely or in part. The weight is rounded up to the next one hundred pounds (100 lbs) and is taken from the inbound Bill of Lading and/or the certified weight ticket. Separate shipments will not be combined. Shipments arriving without a specified weight on the Bill of Lading will be assigned an approximate weight by Brede. This weight will prevail.

Advance Warehouse Shipping Address

- TO: Exhibiting Company Name and Booth #
FOR: E-bike Challenge
Brede Exposition Services
c/o YRC Freight
12400 Dupont Avenue South
Burnsville, MN 55337
- Use this address and information on your inbound bill of lading if shipping your freight to the Advance Warehouse.
 - Please use the freight labels provided in this service manual.
 - Receiving hours: M - F 8:00 a.m. to 4:00 p.m.
 - All shipments must be prepaid: collect shipments will be refused.
 - Brede does not accept shipments that are not consigned to Brede Exposition Services. Such shipments will be refused.
 - **All shipments to the Advance Warehouse must arrive by March 15, 2019 to avoid late charges.**

Direct to Show site Shipping Address

- TO: Exhibiting Company Name and Booth #
FOR: E-bike Challenge
Brede Exposition Services
Minneapolis Convention Center - Hall A
1301 Second Avenue South
Minneapolis, MN 55403
- Use this address and information on your inbound bill of lading if shipping your freight Direct to Show site.
 - Please use the freight labels provided in this service manual.
 - All shipments must be prepaid: collect shipments will be refused.
 - Brede does not accept shipments that are not consigned to Brede Exposition Services. Such shipments will be refused.
 - **Shipments will be received at the facility no sooner than March 21, 2019 during move-in hours.**

Empty Containers, Labels

Exhibitors with crates or boxes that need to be returned to pack up booth equipment at the end of the show must affix empty labels on the containers as soon as they are empty. Empty labels will be available at the Brede Service Desk. Affixing the labels is the sole responsibility of the exhibitor. Brede assumes no responsibility for removal of containers with old empty labels, improper information on labels or valuables stored in containers with empty labels. Empty containers will be removed from the floor and stored until the close of the show. You will not have access to empty containers during the show. In most cases, empty containers may not be stored in your booth during the show as it is a fire hazard.

Outbound Bill of Lading

Outbound shipping is not an automatic process. Outbound Bills of Lading must be completed and turned in to the Brede Service Desk: **do not leave outbound Bills of Lading in your booth.** Exhibitors who wish to ship outbound materials via any carrier other than the show carrier must advise carrier to be checked in at the Brede Service Desk by the driver check-in time specified on the *Show Details* page. Drivers are placed in line for loading on a first-come, first-serve basis, provided the exhibitor is completely packed and a Bill of Lading has been turned in to the Service Desk. Drivers whose Bills of Lading have not been turned in will be placed in a holding queue until the booth is packed and the Bill of Lading is turned in. Should your carrier fail to check in by the designated time, Brede reserves the right to re-route shipment via the official show carrier as necessary, at the exhibitor's expense.



[Find more on Brede.com](http://Brede.com)



phone 612.331.4540
fax 612.331.8380
e-mail sharon.sandvik@brede.com



EXPOSITION SERVICES



Minneapolis Convention Center - Hall A
 Minneapolis, MN
 March 23-24, 2019



Order Form

Submit this form if you will be shipping materials to the advance warehouse or show site. Use the rates and calculator below to estimate your material handling charges. Enter the Material Handling Estimate below on Order Summary / Payment form. Orders received without full payment or credit card information will not be processed.

Material Handling Rate Schedule

- For full definitions and descriptions of all rates, and rules, see the *Material Handling Information* forms included in this manual.
- All material handling fees are calculated on a CWT basis (per hundredweight, or fraction thereof) per shipment, and vary depending on the type of shipment, the amount of handling and the time of day. Separate shipments will not be combined. Minimum charges will apply as shown below. Be sure to review these costs when you prepare your show budget. Contact Brede for assistance in estimating your material handling charges, based upon your specific needs.

Material Handling Rate

Rates below include any applicable OT charges per 100 lbs

Description: A 200 lb minimum charge per shipment applies	
Advance to Warehouse: Crated	\$140.75
Direct to Show site: Crated	\$133.25
Advance to Warehouse: Special Handling	\$175.50
Direct to Show site: Special Handling	\$166.50
Direct to Show site: Uncrated, Unskidded, or Wrapped	\$199.50
Advance to Warehouse/Direct to Show site: Small Packages	\$62.00
Additional Services	
Late shipments, off-target shipments & site shipments received before published move-in or after show opening. Freight received at the warehouse after March 15, 2019 or at show site prior to published move-in or after show opening, add an additional charge per 100 lbs. Additional transportation charges may apply.	\$35.00 per 100 lbs.
Spotting Fee. Any vehicles driven into the exhibit hall under their own power will incur a round-trip spotting fee. Vehicles not moved in under their own power will be unloaded and charged based on weight.	\$180.00 round trip
Special Services. Shipments returned to warehouse will be charged \$20.75 per 100 lbs. with a \$250.00 minimum. Storage will be charged if shipment is not routed or picked up after three working days. Storage fees prior to 30 days before show, or after 3 days following the show are \$2.25 per 100 lbs. per day with a \$35.00 minimum. On-site container storage for freight brought in by exhibitors is \$25.00 per piece.	

Calculate Estimated Material Handling Charges

Select: Advanced Direct

Carrier(s)	Tracking # or Shipped From	Date of Arrival	# Pieces	Est. Weight CWT	Rate per CWT	Estimated Cost 200 lb minimum
					X	= \$
					X	= \$
					X	= \$
Transfer this total to the <i>Order Summary / Payment</i> form. Payment Method must be completed to process orders. Orders received without full payment or credit card will not be processed.					TOTAL	\$

Show Site Contact Name _____ Show Site Phone _____

Exhibiting Company _____

Booth Number

COMPLETE and SUBMIT this form:

by mail Brede Exposition Services | 2211 Broadway St. NE | Minneapolis, MN 55413 | USA by fax 612.331.8380

Material Handling Rates

ADVANCE WAREHOUSE

EXHIBIT MATERIAL

Rush to:

Brede EXPOSITION SERVICES

c/o YRC Freight
12400 Dupont Avenue South
Burnsville, MN 55337

E-bike Challenge

Minneapolis Convention Center - Hall A
Minneapolis, MN
March 23-24, 2019

Exhibitor _____

Booth _____

Late to warehouse charges apply after:

March 15, 2019

ADVANCE WAREHOUSE

EXHIBIT MATERIAL

Rush to:

Brede EXPOSITION SERVICES

c/o YRC Freight
12400 Dupont Avenue South
Burnsville, MN 55337

E-bike Challenge

Minneapolis Convention Center - Hall A
Minneapolis, MN
March 23-24, 2019

Exhibitor _____

Booth _____

Late to warehouse charges apply after:

March 15, 2019

- These shipping labels are provided for your convenience to assist in preparing shipments to the advance warehouse.
- Please cut along dashed lines and affix one to each piece of your shipment to the advance warehouse.
- Please make additional copies of these labels as needed.

Important notes: Warehouse is not temperature controlled.

Hazardous materials will not be accepted at the warehouse.

DIRECT TO SHOW SITE

EXHIBIT MATERIAL

Rush to:

Brede EXPOSITION SERVICES

**Minneapolis Convention Center - Hall A
1301 Second Avenue South
Minneapolis, MN 55403**

E-bike Challenge

**Minneapolis Convention Center - Hall A
Minneapolis, MN
March 23-24, 2019**

Exhibitor _____

Booth _____

**Do not deliver prior to:
March 21, 2019**

DIRECT TO SHOW SITE

EXHIBIT MATERIAL

Rush to:

Brede EXPOSITION SERVICES

**Minneapolis Convention Center - Hall A
1301 Second Avenue South
Minneapolis, MN 55403**

E-bike Challenge

**Minneapolis Convention Center - Hall A
Minneapolis, MN
March 23-24, 2019**

Exhibitor _____

Booth _____

**Do not deliver prior to:
March 21, 2019**

- These shipping labels are provided for your convenience to assist in preparing shipments direct to the show site.
- Please cut along dashed lines and affix one to each piece of your shipment direct to the show site.
- Please make additional copies of these labels as needed.

Important note: Hazardous materials will not be accepted at show site.



Order Form Complete this form to request a pre-printed outbound bill of lading and shipping labels for your outbound shipment. Forms and labels will be delivered to your booth at show site.

Requests must be submitted by: March 8, 2019

Notes

- Please complete one form per shipment.
- Please review the *Material Handling Information*, *Material Handling Rate Schedule*, and *Limits of Liability* forms.
- **Do not leave Bills of Lading in your booth!**

Outbound Shipping Information

Consigned to (Ship to): _____

Attention: _____

Destination (Street Address): _____

City: _____ State: _____ Zip: _____

Method

Ground

YRC Freight Other Ground _____

Air

YRC Freight Other Air _____ Next Day 2nd Day Deferred

Freight Charges Guaranteed By

Company/Exhibitor: _____

Attention: _____

Permanent Street Address: _____

City: _____ State: _____ Zip: _____

Phone: _____ Fax: _____

Shipping Labels Request

Label Request

of Shipping Labels Requested: _____

Exhibitors using FedEx or UPS must provide pre-printed labels with the account number.

Exhibiting Company _____

Booth Number

COMPLETE and SUBMIT this form:

by mail Brede Exposition Services | 2211 Broadway St. NE | Minneapolis, MN 55413 | USA by fax 612.331.8380

Brede

EXPOSITION SERVICES



Minneapolis Convention Center - Hall A
Minneapolis, MN
March 23-24, 2019



Order Form

Submit this form if you would like to order labor from Brede. Labor is available for installation and dismantling of exhibits, and for shrink wrapping and banding of materials. Enter the Total below on Order Summary / Payment form. Orders received without full payment or credit card information will not be processed.

Advance Order Discount Deadline: March 8, 2019

Option A: Brede Supervised

- Option for installation to occur prior to exhibitor's arrival.
 - Reduce at-show expenses and time spent.
 - Labor under Brede supervision is straight time when possible.
- Check for Brede Supervised Labor

Installation

Shipped:

- Warehouse
 Show site

Blueprints/Instructions:

- Attached
 with Display-Crate # _____

Shipment :

- Crates
 Boxes
 Carpet/Pad

Electrical under carpet:

- Yes No

Location: _____

Carpet:

- From Brede
 Shipped
 None

Delivery Date: _____

Special Equipment Required: _____

- Brede Supervision costs **30%** of total labor bill.
- There is a **\$50.00** minimum charge for supervision per installation and dismantle.

Dismantle

An Outbound Bill of Lading must be completed and turned in at the Brede Service Desk.

Please provide the following information:

Ship to: _____
Attn: _____
Address: _____
City, ST, Zip: _____
Official show carrier: Ground Air
Other carrier*: _____

*Show site Bill of Lading prevails.

Option B: Exhibitor Supervised

- All work is performed under direction of the exhibitor.
 - Exhibitor must meet labor at Brede Service Desk at scheduled time.
- Check for Exhibitor Supervised Labor

Show Site Contact: _____
Phone #: _____

Labor Rates

Straight Time	\$102.50
<i>Monday-Friday 8:00a.m. - 4:30p.m.</i>	<i>per person per hour</i>
Overtime	\$168.75
<i>Monday-Friday 4:30 p.m. - 8:00 a.m. All day Saturday, Sunday, and observed union holidays</i>	<i>per person per hour</i>

- One hour minimum** per laborer. Labor is then charged in 1/2 hour increments per laborer.
- Use labor rates at left to complete "Rate per laborer" column based on Straight, Overtime, or Double Time.
- Add Brede Supervision column only if using Option A.
- Multiply Subtotal Labor Cost by .30 for Brede Supervision cost.

Estimate Costs

	Date Time	# Laborers Requested	Est. Hrs. per laborer	Total Hrs.	Rate* per person per hour	Subtotal	Brede Supervision (Subtotal X .30)	Estimated Cost
Installation	_____	X	=	X	= \$	+ \$	= \$	
Dismantle	_____	X	=	X	= \$	+ \$	= \$	

Important Notes

- A 30% surcharge will be assessed to all Late/Floor orders.
- Orders not cancelled prior to move-in will result in a minimum one-hour charge per laborer requested.
- A credit card on file is required when using Brede Exposition Services.
- All charges must be paid prior to close of show.

Calculate Total

Est. Total \$ _____

- Transfer this total to the *Order Summary / Payment* form.
- Payment Method must be completed to process orders.
- Orders without payment source will not be processed.

Exhibiting Company _____

Booth Number

COMPLETE and SUBMIT this form:

by mail Brede Exposition Services | 2211 Broadway St. NE | Minneapolis, MN 55413 | USA by fax 612.331.8380

Labor

Brede

EXPOSITION SERVICES



Minneapolis Convention Center - Hall A
Minneapolis, MN
March 23-24, 2019



Order Form

Submit this form if you wish to rent forklift labor from Brede Exposition Services.
Enter the Total below on Order Summary / Payment form.
Orders received without full payment or credit card information will not be processed.

Advance Order Discount Deadline: March 8, 2019

This service is available to assist you with your setup, unskidding, and/or spotting of machinery once it has been delivered to your booth. You do not need to order forklifts to unload your truck or deliver your freight to your booth from the loading dock.

Please call your Brede Customer Service Representative for a quote if you require a forklift for over 5,000 lbs. capacity, a cage, or a crane.

Forklift Rates

	Up to 5,000 lbs. capacity forklift & operator per hour	Helper per person per hour	
Straight Time Monday-Friday 8:00a.m. - 4:30p.m.	\$214.25	\$102.50	<ul style="list-style-type: none"> • One hour minimum per laborer. • Labor is then charged in 1/2 hour increments per laborer.
Overtime Monday-Friday 4:30 p.m. - 8:00 a.m. All day Saturday, Sunday, and observed union holidays	\$275.75	\$168.75	

Order Details

Describe work to be done:

- Spotting of Equipment
- Installation/Dismantle of Header
- Other _____

Please specify other equipment:

- Straps
- Chains
- Fork Extensions

Four (4) Stage Forklift Required: Yes No

Contact responsible for move-in: _____ Phone #: _____

Estimate Costs

	Date Time	Heaviest Piece (lbs.)	# of Forklifts up to 5,000 lbs. (w/Operator)	Est. Hrs. per Forklift	Rate per hour	Estimated Cost
Installation	_____	_____	_____	X	X \$	= \$
Dismantle	_____	_____	_____	X	X \$	= \$

Important Notes

- 30% surcharge will be assessed to all Late/Floor orders.
- One hour will be charged on orders cancelled without 48 hour notice.
- A credit card on file is required when using Brede Exposition Services.
- All charges must be paid prior to close of show.

Calculate Total

Est. Total \$ _____

- Transfer this total to the Order Summary / Payment form.
- Payment Method must be completed to process orders.
- Orders received without full payment or credit card will not be processed.

Exhibiting Company _____

Booth Number

COMPLETE and SUBMIT this form:

by mail Brede Exposition Services | 2211 Broadway St. NE | Minneapolis, MN 55413 | USA by fax 612.331.8380

Forklift

Brede

EXPOSITION SERVICES

e-bike Challenge hicle

Minneapolis Convention Center - Hall A
Minneapolis, MN
March 23-24, 2019



Order Form

Submit this form if you wish to rent hanging signs labor from Brede Exposition Services. Brede is available for assembly, installation, and removal of any hanging signs. Enter the Total below on Order Summary / Payment form. Orders received without full payment or credit card information will not be processed.

Advance Order Discount Deadline: March 8, 2019

Signs Conditions

- Must conform to show management rules and regulations and facility limitations.
- Must have approved rigging points with the exception of cloth banners.
- Signs requiring electrical must be in working order and in accordance with the National Electrical Code. **(Place electrical order on the appropriate form).**
- A detailed diagram must be forwarded to our office with this completed form prior to the show.

Hanging Signs Rates

	Rate for Lift & Crew <i>Per Hour</i>
Straight Time <i>Monday-Friday 8:00a.m. - 4:30p.m.</i>	\$468.00
Overtime <i>Monday-Friday 4:30 p.m. - 8:00 a.m. All day Saturday, Sunday, and observed union holidays</i>	\$603.25

- The minimum crew consists of an operator, an additional laborer, and the equipment.
- There is a **one hour minimum** per laborer & equipment. Charges are by 1/2 hour increments thereafter for installation.
- There is a **one hour minimum** charge for the removal of hanging signs.
- Materials and Pick Points will be priced as needed.

Order Details

Weight (lbs)	Height (ft)	Length (ft)	Assembly Required
<input type="checkbox"/> Fabric	<input type="checkbox"/> Circle	<input type="checkbox"/> Yes	<input type="checkbox"/> Yes
<input type="checkbox"/> Metal	<input type="checkbox"/> Square	<input type="checkbox"/> No	<input type="checkbox"/> No
<input type="checkbox"/> Wood	<input type="checkbox"/> Triangle	Chain Motor	
<input type="checkbox"/> Truss		<input type="checkbox"/> Yes	
		<input type="checkbox"/> No	

_____ ft from top aisle
(booth # _____)

_____ ft from left side
(booth # _____)

_____ ft from right side
(booth # _____)

_____ ft from bottom aisle
(booth # _____)

_____ ft from top of sign to the floor

Estimate Costs

	Date Time	Hanging Signs Rate	Est. Hrs.	Subtotal Cost	Brede Supervision (Subtotal X .30)	Estimated Cost
Installation	_____	\$ _____	X _____ =	_____	+ \$ _____	= \$ _____
Dismantle	_____	\$ _____	X _____ =	_____	+ \$ _____	= \$ _____

Important Notes

- Brede reserves the right to refuse to hang a sign if, in their opinion, it appears unsafe.
- 30% surcharge will be assessed to all Late/Floor orders.
- Orders cancelled prior to move-in will be charged 50% of the original price.
- Orders cancelled after move-in will be charged a one-hour fee per crew & equipment.
- A credit card on file is required when using Brede Exposition Services.
- All charges must be paid prior to close of show.

Calculate Total

Est. Total \$ _____

- Transfer this total to the *Order Summary / Payment* form.
- Payment Method must be completed to process orders.
- Orders received without full payment or credit card will not be processed.

Exhibiting Company _____

Booth Number

COMPLETE and SUBMIT this form:

by mail Brede Exposition Services | 2211 Broadway St. NE | Minneapolis, MN 55413 | USA by fax 612.331.8380

Hanging Sign

Brede

EXPOSITION SERVICES



Minneapolis Convention Center - Hall A
Minneapolis, MN
March 23-24, 2019



Order Form

Submit this form if the exhibiting company intends to use a contractor other than Brede Exposition Services. If the exhibiting company fails to comply with any or all of the requirements listed below, the non-official contractor will not be permitted to service your exhibit, and Brede Exposition Services must be hired for installation and dismantle labor. The non-official contractor will be able to provide supervision only.

Contractor Requirements

Non-official contractors must use labor supplied by Brede Exposition Services unless the following requirements are fulfilled:

- Exhibitors must return this completed form to Brede Exposition Services at least thirty (30) days prior to the show.
- Non-official contractors must **submit proof of adequate insurance**, in the form of an original policy rider, listing Brede as an additional insured, furnished by their broker to Brede's office no later than thirty (30) days in advance of actual installation dates. This must include a copy of your Worker's Compensation Insurance.
- Non-official contractors must furnish show management the names, addresses and telephone numbers of key executives for emergency contact.
- All personnel must be properly badged at show site.

Non-official installation and dismantle contractors may provide supervision. Non-official contractors are allowed on the exhibit floor only during official installation and dismantle hours, providing the information above is supplied.

Contractor Information

NON-OFFICIAL CONTRACTOR: _____

ADDRESS: _____

PHONE#: _____ FAX#: _____

EMAIL ADDRESS: _____ CELL#: _____

CONTACT IN BOOTH: _____

Exhibiting Company _____

Booth Number

COMPLETE and SUBMIT this form:

by mail Brede Exposition Services | 2211 Broadway St. NE | Minneapolis, MN 55413 | USA by fax 612.331.8380

Non-Official I&D Contractor

Brede

EXPOSITION SERVICES

e-bike Challenge hicle

Minneapolis Convention Center - Hall A
Minneapolis, MN
March 23-24, 2019



Order Form

Submit this form if you wish to order signage from Brede.
Enter the Graphics Total below on Order Summary / Payment form.
Orders received without full payment or credit card information will not be processed.

Advance Order Discount Deadline: March 8, 2019

Standard Sizes

Standard signs are digitally produced with color copy, mounted on white foam board, and include up to 10 words.

Qty	Size	Advance	Standard	Subtotal
_____	11" X 14"	\$ 159.00	\$ 206.75	\$ _____
_____	14" X 22"	\$ 180.75	\$ 234.75	\$ _____
_____	22" X 28"	\$ 216.00	\$ 280.50	\$ _____
_____	28" X 44"	\$ 336.00	\$ 462.75	\$ _____

Indicate sign copy & layout here

*File conversion, retouching, cloning or color correcting may incur additional labor charges.

Custom Sizes

Brede can provide digital graphic reproduction in custom sizes. Please contact us for full-color, photo-quality, high resolution digital printing in virtually any size for banners, exhibit graphics and more.

Length	Width	Square footage	Advance	Standard	Subtotal
_____ X _____	=	_____ X _____	\$23.25 per sq. ft.	\$30.00 per sq. ft.	= \$ _____

Ten (10) sq. ft.
minimum order

- Foamcore
 Masonite
 PVC
 Plexi
 Gatorfoam
 Other _____

Select one

- Vertical
 Horizontal

Special instructions

Graphics

Important Notes

- Orders cancelled will be charged 100% of the original price.
- A credit card on file is required when using Brede Exposition Services.
- All charges must be paid prior to close of show.

Calculate

Subtotal \$ _____
 8.025% MN Tax \$ _____
Signs Total \$ _____

- Transfer this total to the Order Summary / Payment form.
- Payment Method must be completed to process orders.
- Orders received without full payment or credit card will not be processed.

Exhibiting Company _____

Booth Number

COMPLETE and SUBMIT this form:

by mail Brede Exposition Services | 2211 Broadway St. NE | Minneapolis, MN 55413 | USA by fax 612.331.8380